

28L0138-40R-10

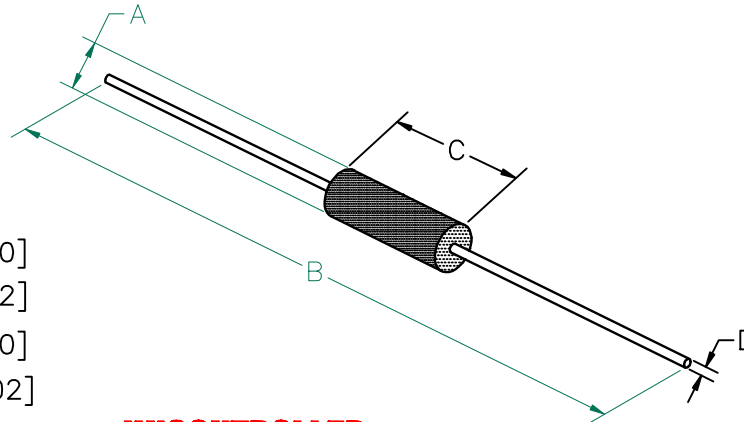

PHYSICAL DIMENSIONS:

A	3.51 [.138]	+ 0.25 [.010]
B	59.00 [2.32]	+ 1.57 [.062]
C	8.89 [.350]	+ 0.51 [.020]
D	0.64 [.025]	+ 0.05 [.002]

UNCONTROLLED DOCUMENT

ELECTRICAL CHARACTERISTICS:				
	Z (Ω) @		DCR (Ω)	Rated Current
	25 MHz	100MHz		
Nominal	99	135		
Minimum	-	101		
Maximum	-	169	0.01	5,000 mA



|Z| , R, AND X vs. FREQUENCY

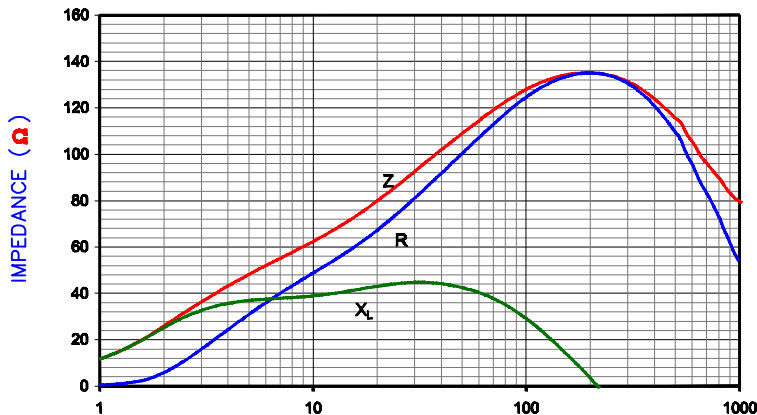

NOTES: UNLESS OTHERWISE SPECIFIED

1. TAPED AND REELED per CURRENT EIA SPECIFICATIONS 14" REELS, 4500 PCS/REEL.
2. COMPONENTS SHOULD BE ADEQUATELY PREHEATED BEFORE SOLDERING.
3. WIRE: C10200 OXYGEN FREE COPPER (99.95 MIN.) 22AWG (.025 DIA.)
4. PLATING: 100% TIN 5μ ± 2μ [200 μin ± 80μin]
5. WEIGHT/1000: .411 kgs. .905 lbs.
6. REFERENCE STEWARD CORE P/N 28B0138-*00.

DIMENSIONS ARE IN mm (INCHES).				THIS DOCUMENT CONTAINS INFORMATION WHICH IS PROPRIETARY AND CONFIDENTIAL TO STEWARD. NO PRODUCTION OR PUBLICATION OF THIS DOCUMENT IN WHOLE OR IN PART SHALL BE MADE WITHOUT WRITTEN AUTHORIZATION FROM STEWARD.			
H	ADD ROHS SYMB. UPDATE COMPANY LOGO	04/20/07	JRK				
G	CHANGE P/N (ADD -10) CHG NOTE 3 ADD NO LEAD SYMBOL, CORRECT WGT.	10/14/03	JRK				
F	UPDATE FORMAT, CHG RATED CURRENT FROM 10,000 ADDED NOTES	10/11/01	JRK				
E	ADDED (*NOTE&DIM) ON SHT30F4 CORRECTED DIM D ON SHEET 20F4	10/13/98	DTR	PROJECT/PART NUMBER:	REV	PART TYPE:	DRAWN BY:
D	SEE PAGE 30F4 FOR CHGS	07/15/98	DTR	28L0138-40R-10	H	ASSEMBLY	DTR
C	UPDATE PRINT FORMAT	06/25/98	DTR	06/30/98	SCALE:	NTS	SHEET:
REV	DESCRIPTION	DATE	INT	28L0138-40R-10-2-H	TOOL #:	B0138	2 of 3